

پودمان پنجم

كسب اطلاعات فنی (زبان فنی)

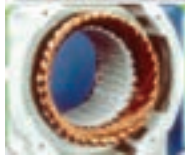

Winding

- One or more turns of wire forming a continuous coil through which an electric current can pass, as used in transformers, generators, etc

What Does an Electrician Need to Do the Job?

Manuel uses many tools on his job. A few of these are screwdrivers, knives, pliers, and wire cutters. Electricians' tools have special insulation on them. This means they have a coating that prevents Manuel from getting hurt by the electricity.

Think of all the things in a home that use electricity. It takes a lot of electrical power to make all of those things work. Homes with electricity depend on **circuit breakers**.

Reading: DC Circuit Theory

The fundamental relationship between voltage, current and resistance in an electrical or electronic circuit is called Ohm's Law.

All materials are made up from atoms, and all atoms consist of protons, neutrons and electrons. Protons have a positive electrical charge. Neutrons have no electrical charge while Electrons, have a negative electrical charge. Atoms are bound together by powerful forces of attraction existing between the atoms nucleus and the electrons in its outer shell.

واحد یادگیری ۱

آیا می‌دانید که

- ۱- چگونه می‌توان المان‌های الکتریکی را در یک جمله ساده به زبان انگلیسی تعریف کرد؟
- ۲- کاربرد کاتالوگ‌های فنی تجهیزات برقی چه فوایدی دارد؟
- ۳- دانستن زبان فنی در توسعه و رشد شایستگی در حوزه شغلی یک برقکار چه تأثیری دارد؟

پس از اتمام این پودمان هنرجویان قادر خواهند بود متون ساده فنی رشته برق را به زبان فارسی برگردانند و علاوه بر آشنایی با واژگان و اصطلاحات پرکاربرد تخصصی حوزه شغلی خود، کاتالوگ‌ها و بروشورهای تجهیزاتی برقی را برای استفاده بهینه آنها تغییر دهند.

استاندارد
عملکرد



مقدمه

توانایی کافی استفاده از متون و منابع فنی و فهم واژه‌ها و اصطلاحات انگلیسی در بسیاری از مشاغل ضروری است. برقکاران نیز باید برای ارتقای سطح دانش حرفه و شغلی خود، تسلط لازم در بهره‌گیری از راهنماها و دستورالعمل‌های بهره‌برداری و نگهداری تجهیزات (کاتالوگ‌ها) مرتبط با رشته خود را به زبان انگلیسی داشته باشند.

توسعه مهارت آموزی زبان فنی انگلیسی بین سطوح مختلف شغلی کارگر ماهر، تکنسین‌ها و مهندسان، آنها را قادر به ارتقا و هم‌افزایی دانش فنی درمحل کار می‌کند.

هدف اصلی این پودمان، آموزش زبان فنی به هنرجویان رشته الکتروتکنیک است. به طوری که قادر به درک مفاهیم برقی از متون فنی، کاتالوگ‌خوانی و راهنمای استفاده از تجهیزات مختلف برقی باشند.

استفاده از منوی HELP نرم افزارهای تخصصی، آشنایی با اصطلاحات پر تکرار در زمینه تخصصی رشته برق، الگوهای مصرف انرژی، نکات مربوط به ایمنی و بهداشت از دیگر اهداف این پودمان است. این پودمان از سه بخش اصلی تشکیل شده است:

- اندازه‌گیری الکتریکی
- ولتاژ مستقیم و متناوب (نیمه تجویزی)
- انواع کاتالوگ

در شروع هر بخش اصلی، ابتدا لغات پر کاربرد تخصصی آن بخش با مفهوم آنها بیان شده است. در ادامه مکالمه مختصری در زمینه موضوع مورد نظر آورده شده و در نهایت برای آن یک درک مطلب بیان شده است. برای عمق دهی به یادگیری بیشتر در خلال هر موضوع، فعالیت‌هایی نیز ارائه شده است.

هنرجویان عزیز، برای دریافت معانی کلمات و لغات تخصصی در این پودمان از واژگان تخصصی آورده شده در کتاب همراه هنرجو استفاده نمایید. در کتاب همراه، معانی کلمات تخصصی به زبان فارسی آورده شده است.

توجه



۱-۵- اندازه‌گیری الکتریکی (Electrical Measurement)

مقدمه

Multi_meter is a handy tool that you use to measure electricity. Almost all multimeters can measure voltage, current, and resistance. Most multi-meters also use metric prefixes. Metric prefixes work the same way with units of electricity as they do with other units you might be more familiar with, like distance and mass. For example, you probably know that a meter is a unit of distance, a kilometer is one thousand meters, and a millimeter is one thousandth of a meter. The same applies to milligrams, grams, and kilograms for mass. Here are the common metric prefixes you will find on most multimeters:

μ (micro): one millionth

m (milli): one thousandth

k (kilo): one thousand

M: (mega): one million

These metric prefixes are used in the same way for volts, amps, and ohms. For example, $200k\Omega$ is pronounced “two hundred kilo-ohms,” and means two hundred thousand (200,000) ohms. The voltage, current and resistance with multimeter are measured as follows:

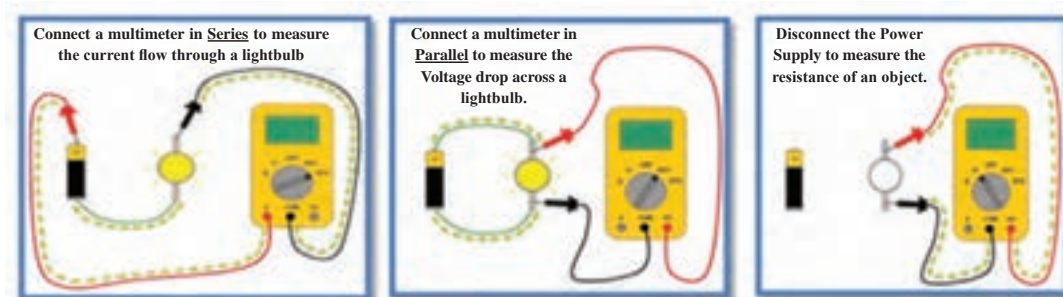



Resistance

- Opposition to the flow of current.



Capacitor

- Device which stores electricity when an operation is in progress.



Diode

- In electronics, a diode is a two-terminal electronic component that conducts electric current in only direction.



Transistor

- Small electrical component used to amplify voltage, output or current.



Inductor

- An inductor is a passive two-terminal electrical component that stores electrical energy in a magnetic field when electric current flows through it.

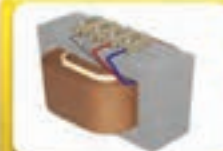

Transformer

- alternating (A/C) current of a certain voltage to an alternating current of different voltage, without change of frequency, by electromagnetic induction.



Electric motor

- An electric motor is an electrical machine that converts electrical energy into mechanical energy. The reverse of this is the conversion of mechanical energy into electrical energy and is done by an electric generator, which has much in common with a motor.

Conversation

مکالمه

A: Welcome, can I help you with anything?

B: Hi, I need a device to measure the voltage and current, do you have any suggestions?

A: Yes, I suggest you a Multi-meter. Multi-meter is performance device for measuring voltage, current and resistance and etc.

As u can see, different part of the device is specified.

- Display: Where measurement readouts can be viewed.
- Buttons: For selecting various functions;
- Dial (or rotary switch): For selecting primary measurement values (volts, amps, ohms).
- Input jacks: Where test leads are inserted.



B: Can the ac voltage be measured with it?

A: Yes, please see the device,



Use the V with a straight line to measure DC Voltage

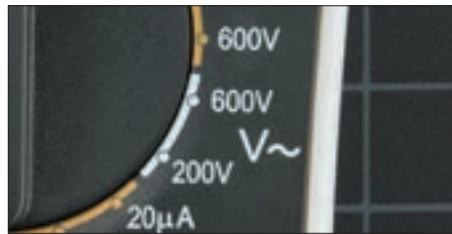

Use the V with a wavy line to measure AC Voltage

B: Great! Can you explain me more about input port the device?

A: Yes,



① A (amps)

Red test lead input for:

- Current measurements of up to 10.00 amps.
- Current measurements of frequency and duty cycle.

② mA, μ A (milliamps, micro amps)

Red test lead input for:

- Current measurements of 0 microamps (μ A) to 400 milliamps (mA; up to 600 mA for 18 hours).
- Current measurements of frequency and duty cycle.
- Optional mA output current clamp for measurements of up to 600 amps ac.

③ COM

Black test lead input for:

- All measurements.
- Low/negative connection for circuit measurements or accessories.
- Alternately known as “return terminal.” COM is short for common.

④ Voltage (V), resistance (Ω), diode test ($\rightarrow|+$), capacitance ($-|+$), temperature.

Red test lead input for:

- Measurements for voltage, resistance, diode, capacitance, frequency, duty cycle.

B: Thanks a lot. How can I measure voltage and current or resistance with this device?

A: Connect the multi-meter in series to measure the current flow,

Connect the multi-meter in parallel to measure the voltage drop,
Disconnect the power supply to measure the resistance.

B: I'll I would like to buy the device.

A: Will this be cash or charge?

B: Here, take my credit card.

A: Just sign here, please.

B: Sure. Here you go.

A: Here's your receipt. Please read the catalogue for optimal use.

Have a nice day.

Activity

فعالیت

Determine the Persian equivalents of the following technical terms and write them.



Plase study a Multi-meter catalogue and translate important section.

After Volta's battery was invented in 1600, the first utilization of electricity was in telegraphic communication. What kind of measuring instrument was required for telegraphic communication? Probably, neither voltage nor current needed to be measured regularly. Measurement was necessary only at times of failure or in preparation. Even when trans-Atlantic telegraphic communication was successfully completed in 1866, the Kelvin Mirror Galvanometer was used as a telegraphic receiving instrument. In other words, a measuring instrument as an electric component was not independently used.

When the electric power industry began to develop in the second half of the 19th century, current and voltage needed to be measured regularly. One of the engineers who put the precision DC ammeter into practical use was Edward Weston (1850_1936). He named the meter the Portable Instrument, as the electric meters until then could be used only in the laboratory, and could not be transported anywhere to make measurements.

In 1886 Weston completed a portable DC ammeter with an accuracy of 0.5%, and subsequently aimed at creating an ammeter for large currents and an AC meter. For that purpose, he invented stable resistance Manganin. In fact, the key component of the meter was a stable permanent magnet and the supporting mechanism of the pivot.

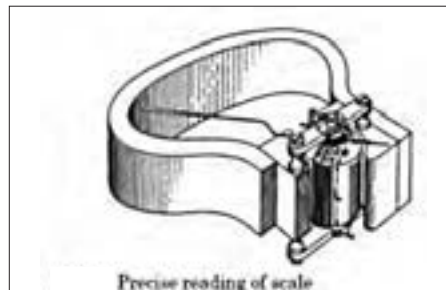
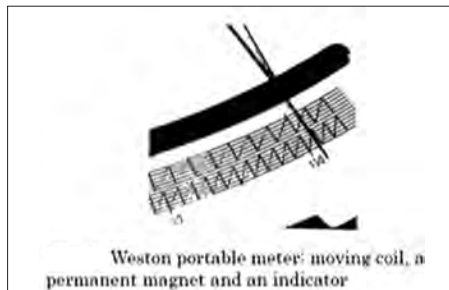

DC Circuit Theory

The fundamental relationship between voltage, current and resistance in an electrical or electronic circuit is called Ohm's Law.

All materials are made up from atoms, and all atoms consist of protons, neutrons and

electrons. Protons have a positive electrical charge. Neutrons have no electrical charge while Electrons, have a negative electrical charge. Atoms are bound together by powerful forces of attraction existing between the atoms nucleus and the electrons in its outer shell. When these protons, neutrons and electrons are together within the atom they are happy and stable. But if we separate them from each other they want to reform and start to exert a potential of attraction called a *potential difference*.

Now if we create a closed circuit these loose electrons will start to move and drift back to the protons due to their attraction creating a flow of electrons. This flow of electrons is called an **electrical current**. The electrons do not flow freely through the circuit as the material they move through creates a restriction to the electron flow. This restriction is called resistance.

Then all basic electrical or electronic circuits consist of three separate but very much related electrical quantities called: Voltage, (v), Current, (i) and Resistance, (Ω).

Electrical Voltage

Voltage, (V) is the potential energy of an electrical supply stored in the form of an electrical charge. Voltage can be thought of as the force that pushes electrons through a conductor and the greater the voltage the greater is its ability to “push” the electrons through a given circuit. As energy has the ability to do work this potential energy can be described as the work required in joules to move electrons in the form of an electrical current around a circuit from one point or node to another.

Then the difference in voltage between any two points, connections or junctions (called nodes) in a circuit is known as the Potential Difference, commonly called the Voltage Drop.

A constant voltage source is called a DC Voltage with a voltage that varies periodically with time is called an AC voltage.

Batteries or power supplies are mostly used to produce a steady D.C. (direct current) voltage source such as 5v, 12v, 24v etc in electronic circuits and systems. While A.C. (alternating current) voltage sources are available for domestic house and industrial power and lighting as well as power transmission.

Voltage Symbols

A simple relationship can be made between a tank of water and a voltage supply. The higher the water tank above the outlet the greater the pressure of the water as more energy is released, the higher the voltage the greater the potential energy as more electrons are released.

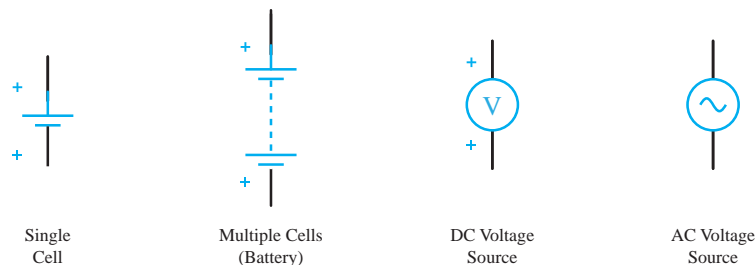

Electrical Current, (I) is the movement or flow of electrical charge and is measured in Amperes, symbol i , for *intensity*). It is the continuous and uniform flow (called a drift) of electrons (the negative particles of an atom) around a circuit that are being “pushed” by the voltage source

Generally in circuit diagrams the flow of current through the circuit usually has an arrow associated with the symbol, I, or lowercase i to indicate the actual direction of the current flow. However, this arrow usually indicates the direction of conventional current flow and not necessarily the direction of the actual flow.

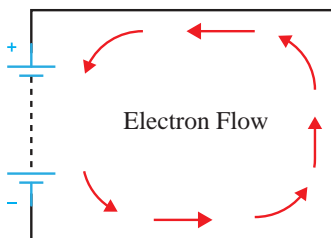

The flow of electrons around the circuit is opposite to the direction of the conventional current flow being negative to positive. The actual current flowing in an electrical circuit is composed of electrons that flow from the negative pole of the battery (the cathode) and return back to the positive pole (the anode) of the battery.

This is because the charge on an electron is negative by definition and so is attracted to the positive terminal. This flow of electrons is called **Electron Current Flow**. Therefore, electrons actually flow around a circuit from the negative terminal to the positive.

Current is measured in Amps and an amp or ampere is defined as the number of electrons or charge passing a certain point in the circuit in one second.

Resistance, (R) is the capacity of a material to resist or prevent the flow of current or, more specifically, the flow of electric charge within a circuit. The circuit element which does this perfectly is called the “Resistor”.

Resistance is a circuit element measured in Ohms, Greek symbol (Ω , Omega) with prefixes used to denote Kilo-ohms ($k\Omega = 10^3\Omega$) and Mega-ohms ($M\Omega = 10^6\Omega$). Note that resistance cannot be negative in value only positive.

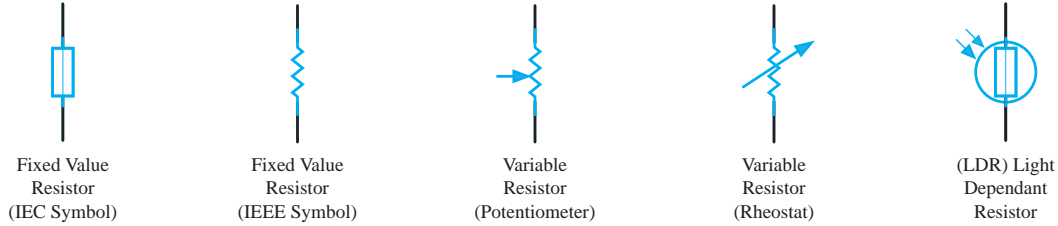

Resistor Symbols

The amount of resistance a resistor has is determined by the relationship of the current through it to the voltage across it which determines whether the circuit element is a “good conductor” - low resistance, or a “bad conductor” - high resistance. Low resistance, for example 1Ω or less implies that the circuit is a good conductor made from materials such as copper, aluminium or carbon while a high resistance, $1M\Omega$ or more implies the circuit is a bad conductor made from insulating materials such as glass, porcelain or plastic.

The relationship between Voltage, (v) and Current, (i) in a circuit of constant Resistance, (R) would produce a straight line i-v relationship with slope equal to the value of the resistance as shown.

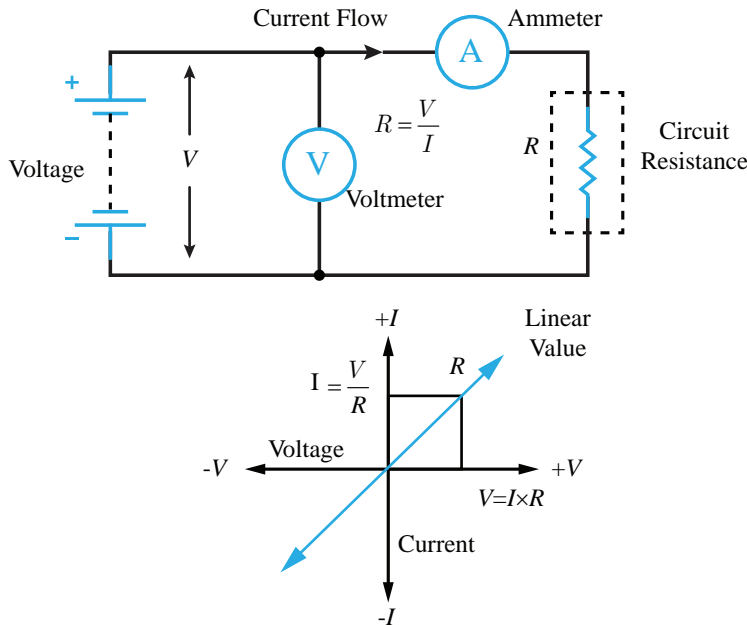

Voltage, Current and Resistance Summary

Hopefully by now you should have some idea of how electrical Voltage, Current and

Resistance are closely related together. The relationship between **Voltage, Current** and **Resistance** forms the basis of Ohm's law. In a linear circuit of fixed resistance, if we increase the voltage, the current goes up, and similarly, if we decrease the voltage, the current goes down. This means that if the voltage is high the current is high, and if the voltage is low the current is low.

Likewise, if we increase the resistance, the current goes down for a given voltage and if we decrease the resistance the current goes up.

A. read each statement and decide whether it is true or false.

Write T before true statement and F before false statements.

..... 1_ Neutrons have positive and negative electrical charges.

..... 2_ Voltage that varies periodically with time is called an DC voltage.

..... 3_ Electrons flow from the negative (-ve) terminal to the positive (+ve) terminal of the supply.

..... 4_ We decrease the resistance the current goes up.

.....5_ For ease of circuit understanding conventional current flow assumes that the current flows

from the negative to the positive terminal.

.....6_ Current is measured in Amps and an amp or ampere is defined as the number of protons.



B. Answer the following questions orally.

1_ when atom is stable?

2_ what is a voltage drop?

3_ How does the current and resistance change, when voltage rises?

4_ what is the resistance?

5_ how does the electrical flow change with the change resistance?

C. Please define the words according to the text.

Voltage

Electrical Current:

Electron Flow:

Resistance:

Potential Difference:

Read and practice and translate to Persian

ترجمه کنید

What Does an Electrician Need to Do the Job?

Manuel uses many tools on his job. A few of these are screwdrivers, knives, pliers, and wire cutters. Electricians' tools have special insulation on them. This means they have a coating that prevents Manuel from getting hurt by the electricity. Think of all the things in a home that use electricity. It takes a lot of electrical power to make all of those things work. Homes with electricity depend on **circuit breakers**.

Where Does an Electrician Work?

Electricians work in many different places. Manuel works with electricity where people are building new businesses. These are called commercial buildings. He also works in new homes that are being built. Other electricians work in maintenance. Has a big storm ever stopped the electricity in your neighborhood? A maintenance electrician probably fixed the power lines to bring back the electricity.

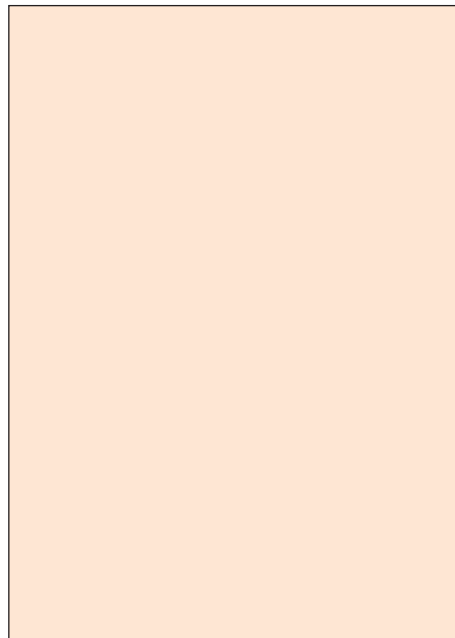
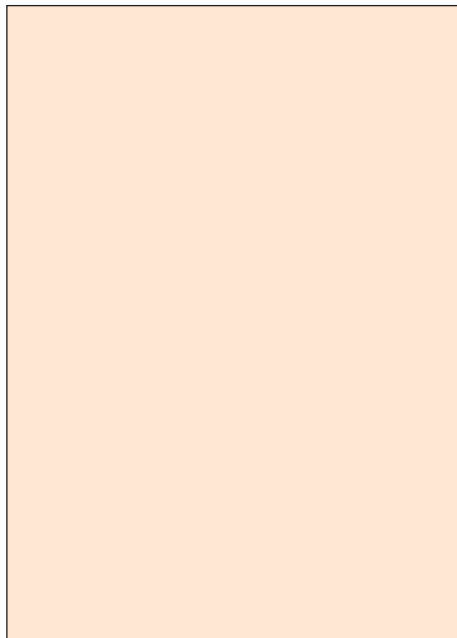

a. Determine the Persian equivalents of the following technical terms and write them.

Hair dryer

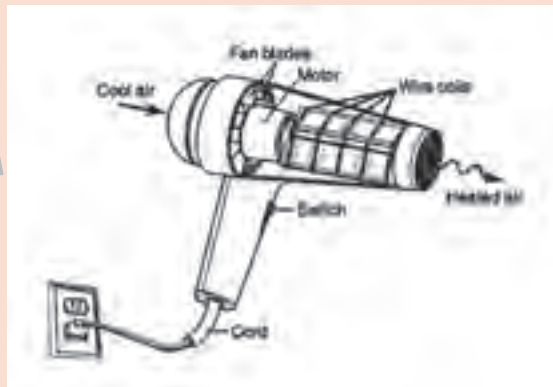

b. Write the words that mean the same under the picture where they belong.

Screw driver

Pliers

Toolbox

Wire cutter

Nose pliers

Mains tester

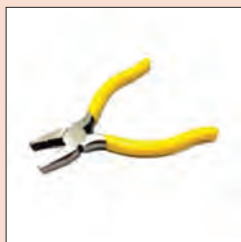

the magnetic field

As you can see by the attraction and repulsion of the magnetic poles. there are forces coming out of the magnetic poles to cause those actions. But the actions do not only take Place at the poles. The magnetic force actually surrounds the magnet in a field. This can be seen when a compass is moved around the bar magnet. In each position around the bar magnet, one end of the compass needle will point to the opposite pole on the bar.



The compass shows how the magnetic force surrounds a magnet

The compass can also be used to see how far the magnetic field extends away from the magnet. By withdrawing the compass slowly, you will reach a point where the compass needle is no longer affected by the magnetic field of the magnet, but will again be attracted by the earth's north magnetic pole.

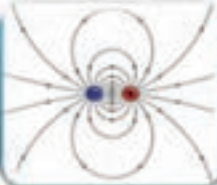

Magnetic field

- a region of space near a magnet, electric current, or moving charged particle in which a magnetic force acts on any other magnet, electric current, or moving charged particle.



Magnetic flux

- A measure of the quantity of magnetism, being the total number of magnetic lines of force passing through a specified area in a magnetic field.



Magnetic Core

- A magnetic core is a piece of magnetic material with a high magnetic permeability used to confine and guide magnetic fields in electrical, electromechanical and magnetic devices.

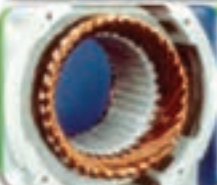

Winding

- One or more turns of wire forming a continuous coil through which an electric current can pass, as used in transformers, generators, etc.



Isolator

- A mechanical switching device used to isolate an electrical system or part of an electrical system.



Fuse

- Electrical safety device that operates to provide over current protection of an electrical circuit.



Switch

- A mechanical device which is capable of making and breaking current under normal load conditions.

Conversation

A: Hello Friends. Welcome in Iran Transfo Company.

Today we are visiting transformer production line and talking about transformer. Ask any question.

B: What is a transformer?

A: The transformer is an electromagnetic static device, which is used to transfer the electrical energy from one level to another level without changing the frequency. It can increase or decrease the voltage with the corresponding decrease and increase in current keeping the power of transformation as same. A transformer can change high voltage to low voltage and low voltage to high voltage but in both cases the frequency remains unchanged.

C: Excuse me, Transformer consists of what parts?



A: As you see, the transformer consists of an iron core, with two windings on it. These two windings are insulated to each other and to the iron core and there is no electrical connection between them. Thank you for good questions, Next question.



B: What kinds of basic Types of Transformers?

A: step up transformer, if a transformer changes low voltage to high voltage, it is known as the step up transformer.



Step down transformer, the transformer which changes the high voltage into low voltage is known as the step down transformer.

D: What types of connection are the transformer?

A: Three forms of connection are possible: Star, Delta and zig zag.

Well, now I'm asking a question. What is the function of the oil in a transformer?

Does anyone know why? No one has an opinion?

Ok, I tell you,

There are two function of oil in transformer,

Cooler and insulator.

Activity

فعالیت

1_ Please research about Iran Transfo Company



2_ Please study what frequency transformer remains unchanged.

History

تاریخچه

Magnetism was first discovered over 2000 years ago by the ancient Greeks when they noticed that a certain kind of stone was attracted to iron. Since this stone was first found in Magnesia in Asia Minor, the stone was called *Magnetite*. Later, when it was discovered that this stone would align itself north and south when suspended on a string, it was referred to as the leading stone or Lodestone. Lodestone, therefore, is a natural magnet that attract magnetic materials.



Reading

درک مطلب

The most famous of the three visionary men, Edison, developed the world's first practical light bulb in the late 1870s, then began building a system for producing and distributing electricity so businesses and homes could use his new invention. He opened his first power plant, in New York City, in 1882. Two years later, Tesla, a young Serbian engineer, immigrated to America and went to work for Edison. Tesla helped improve Edison's DC



generators while also attempting to interest his boss in an AC motor he'd been developing; however, the Wizard of Menlo Park, a firm supporter of DC, claimed AC had no future. Tesla quit his job in 1885 and a few years later received a number of patents for his AC technology. In 1888, he sold his patents to industrialist George Westinghouse, whose Westinghouse Electric Company had quickly become an Edison competitor.

Read and practice and translate the Persian

ترجمه کنید و پاسخ دهید

DC vs. AC

Direct current (DC) electricity comes from sources such as batteries, photovoltaic (PV) modules, and DC generators. DC voltage doesn't change polarity—the positive pole always has a positive voltage with respect to the negative pole. Since charges flow from a higher potential (voltage) to a lower potential, DC provides a constant, unidirectional flow.

Alternating current (AC) electricity is produced from rotating generators and can now be synthesized by inverters and variable-speed motor drives. The familiar AC voltage takes the form of a sine wave, with the voltage's magnitude constantly changing and reversing polarity. The current also changes constantly and reverses direction each cycle. (For more information about AC and DC electricity, see the two-part article in *HP52* and *HP53*, "Basics of Alternating Current Electricity," and *Word Power* in *HP55* and *HP56*.)

How DC & AC Generators Work

Both DC and AC generators use Faraday's principle of induction, which says that when a conductor moves through a magnetic field, a voltage is induced. A rotating loop of wire (armature) cuts and stretches the magnetic lines of force, as the conductors pass the field face, generating voltage.

At other times during the rotation, when the loop is traveling parallel to the magnetic lines of force, no voltage is generated. The polarity of the voltage induced in the left and right segments depends on whether they are traveling down through the field, and then traveling up a half-turn later. With each rotation, the voltage reverses, generating one cycle of AC.

When scientists first sought to generate electricity from machines, they wanted the same steady flow that batteries provided. American blacksmith Thomas Davenport invented the commutator, a mechanical device to make an alternator's current unidirectional. The commutator acts like a high-speed switch, switching the load just as the generator's voltage drops to zero, ensuring that the load's current and voltage do not reverse. Practical DC generators use many armature windings and commutator segments to minimize ripple in the output voltage.

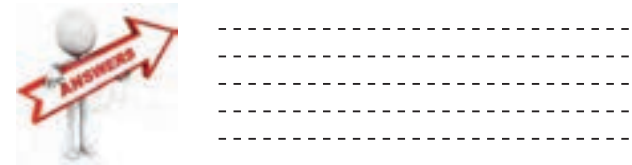
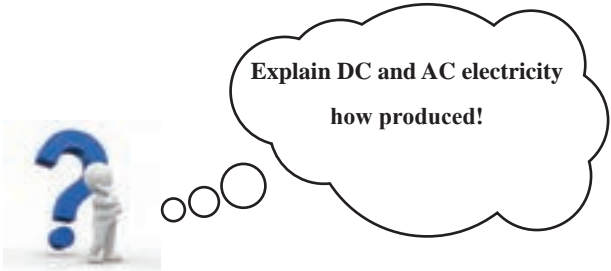

How is generating one cycle of AC?

 What is a commutator?

 How to minimize ripple in the DC generator output voltage?

 How flow charges in DC voltage?



A. read each statement and decided whether it is true or false. Write T before true statement and F before false statements.

- 1_ Just DC generators use Faraday’s principle of induction.
- 2_ AC electricity can now be synthesized by invertors and fix-speed motor drive.
- 3_ In DC voltage, the positive pole always has a positive voltage with respect to the negative pole.
- 4_ AC voltage takes the form of sine wave.
-5_ when the conductor moves through a magnetic field, voltage is induced.

B. See the movie.



C. What was the invention of Tesla?

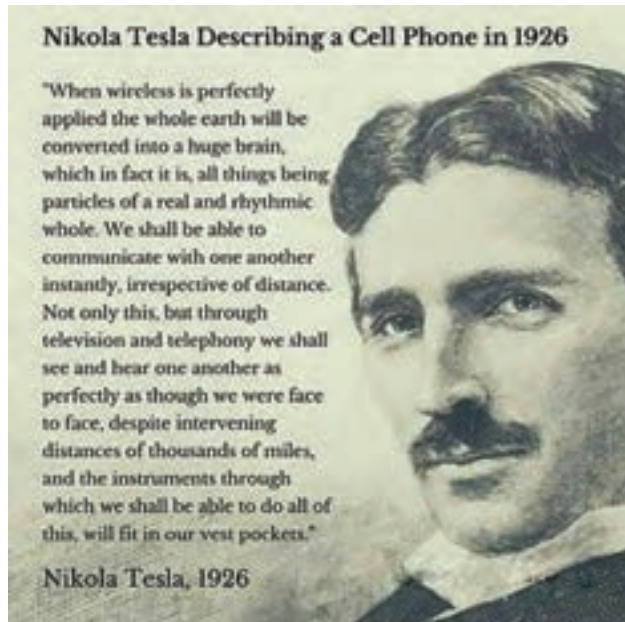

D. Read and practice and write summary of the text.

.....

.....

.....

.....

.....

.....

.....

.....

.....

.....

Transformer nameplates

پلاک ترانسفورماتور

Transformer nameplates contain several standard items of information and other optional information. Transformer nameplate must specify the following parameters:

- Volt_Ampere (VA) or kilovolt_amperes (kVA) rating
- The voltage rating of both the primary and secondary circuits

- The impedance rating of the transformer (normally restricted to 25 kVA or larger)
- The required clearances for transformers with ventilated openings
- The amount and kind of insulating liquid where used.
- On dry-type transformers (no liquid coolant or insulation), the nameplate listing must also include the class temperature rating of the winding insulation.

Other items that may be on the nameplate include the number of phases, a Wiring diagram, and tap-changing information.

Transformer Nameplate Information

Following are the key information which are provided on the transformer nameplate from the manufacturer.

Serial number	Number of phases
Frequency	Voltage rating
kVA Rating	Temperature Rise
Polarity	Percentage Impedance
Connection Diagram	Name of Manufacturer
Type of insulating liquid	Conductor Material for each Winding
Basic Insulation Level (BIL)	Total Weight (kg)

Transformer kVA Rating

The nameplate always indicates the size of the transformer in terms of how much apparent power (rated kVA) it is designed to deliver to the load on a continuous basis. By its very nature, the transformer will have more than one rated voltage, depending on which side we are looking at and how many windings there are on that side.

Transformer Voltage Ratings

The following is a list of some conventions for specifying transformer voltage ratings:

U_W

The dash between the voltages U and W indicates they are on different sides of the transformer. For example 480_120 tells us the primary winding is rated 480 V and the secondary is rated 120 V.

U/W

The slash indicates the two voltages are from the same winding and that both voltages are available;

l_ g., 120/240 can indicate a 240 volt winding with a center tap.

U×W

The cross indicates a two-part winding that can be connected in series or parallel to give higher voltage or current, respectively. Only one voltage is available at a time; e.g., 120×40 indicates the transformer can operate at 120 V or 240 V, but not both simultaneously.

U Y/W

The Y indicates a three-phase winding connected in a wye configuration. The first letter (U) is the line voltage and the second letter (W) is the phase voltage (line to neutral). Clearly, $U = \sqrt{3} W$. Examples include 208Y/ 120 and 480Y/277.

Transformer Rated Frequency

The rated frequency will also be indicated on the nameplate (usually 60 Hz for the United States). Operating the transformer at a lower frequency will increase the core flux unless the voltage is reduced, this could cause magnetic saturation of the core and overheating due to increased hysteresis and eddy current losses.

Maximum Temperature Rise

The maximum allowable temperature rise for the transformer is also shown on the nameplate and is based on an assumed ambient temperature of 30°C.

Insulation Class

The insulation class indicates the type of transformer insulation.

Transformer Percentage Impedance

Percent impedance is a representation of the impedance of the windings referred to one side of the transformer. This number is the percentage of rated voltage that must be applied to the high side to cause rated current on the low side when the low side is shorted.

3_ Write the parameters from the Transformer nameplate.

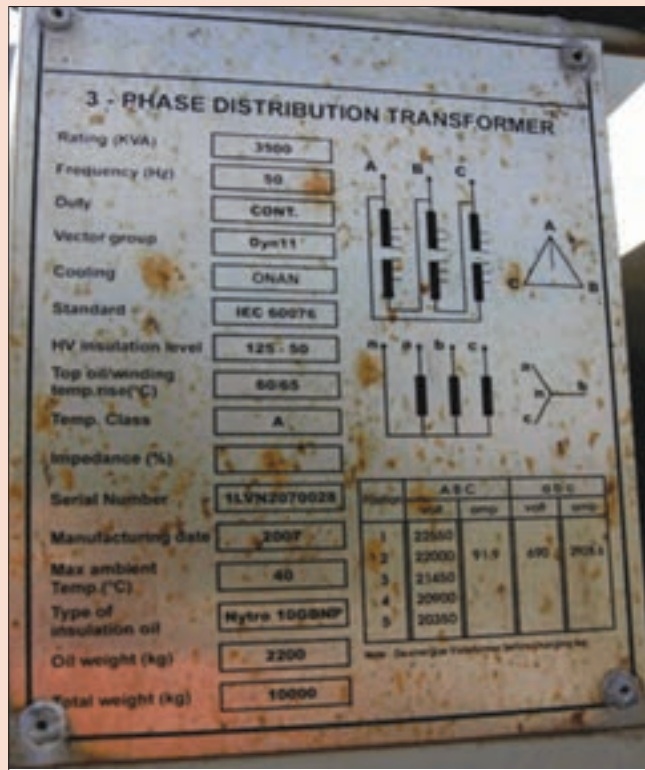

Serial number	Number of phases.....
Frequency.....	Voltage rating.....
kVA Rating.....	Temperature Rise.....
Polarity.....	Percentage Impedance.....
Connection Diagram.....	Name of Manufacturer.....
Type of insulating liquid.....	Conductor Material for each Winding
Basic Insulation Level (BIL)	Total Weight (kg)

۳-۵- انواع کاتالوگ (kinds of Catalogue)

مقدمه

For the optimal use of a device, the first step is to study the catalogue of that device. In the catalogues, information and technical specifications, safety and maintenance as well as how to install and operate the device is well described.

By studying the catalogue, the electrician gets to know different parts of the device, functions and suitable use. Also, depending on the type of device, the risks and warnings are also expressed in catalogue.

In electrical device, catalogues have a several types, typically such as Labels, nameplates, User manual or User guides, Data sheets and folded catalogues. For example, the part of solar charge controller Data sheet is shown. In this part wiring is shown, Step by step explain wiring and components connecting the system.

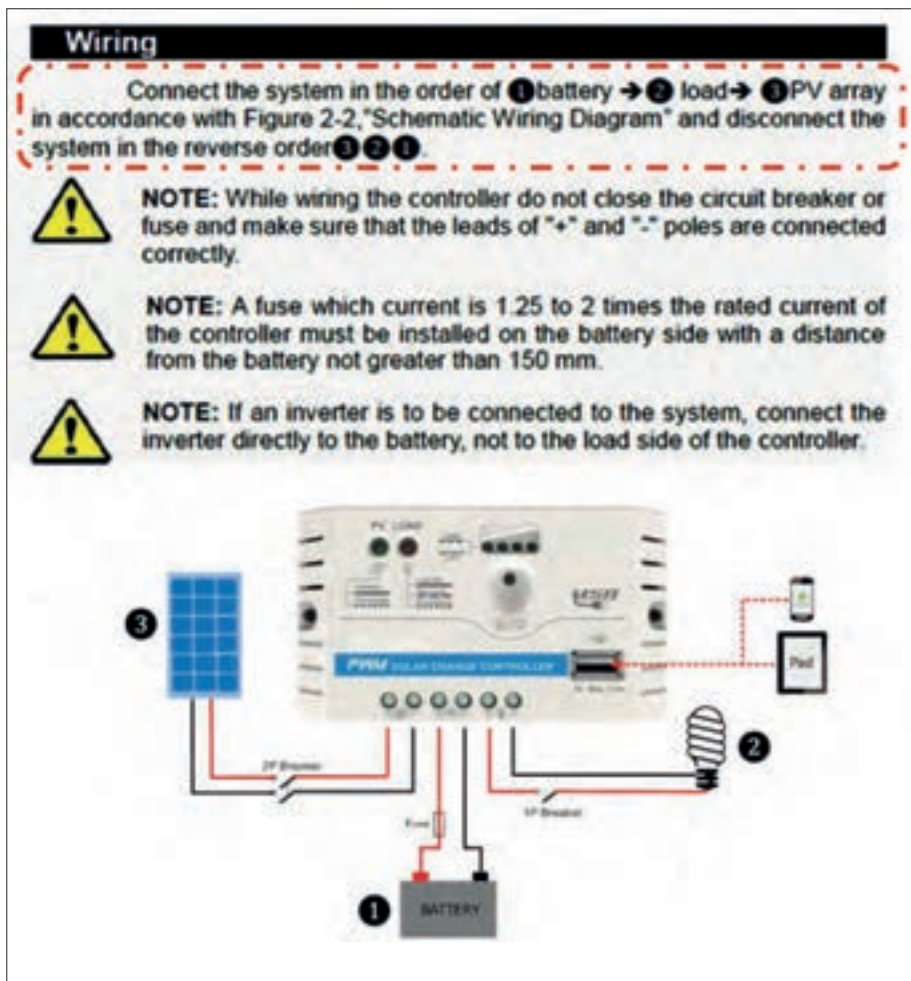

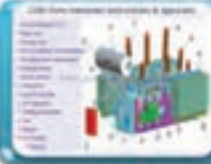

Technical Specification

- A **technical specification** is a document that defines a set of requirements that a product or assembly must meet or exceed.



User Manual

- A user guide or user's guide, also commonly known as a manual, is a technical communication document intended to give assistance to people using a particular system.



Safety Information

- A set of principles and regulations that can be used to protect capital and human resources against industrial hazards effectively.



wiring

- **Wiring** is an electrical installation of cabling and associated devices such as switches, distribution boards, sockets and light fittings in a structure.



Troubleshooting

- **Troubleshooting** is a form of problem solving, often applied to repair failed products or processes on a machine or a system.



Power supply

- A power supply is an electrical device that supplies electric power to an electrical load. The primary function of a power supply is to convert electric current from a source to the correct voltage, current, and frequency to power the load.



Structure

- a device or other object constructed from several parts.

We go to Bandar Abbas. We go to Ms. Mohamadi's house. She is one of the successful entrepreneurs in Iran.



Reporter: How are you? Please explain about your work.

Ms. Mohamadi: I have set up a photovoltaic system. The system generates electricity from solar energy.

Reporter: Great! How much do you earn from this system every month?

Ms. Mohamadi: About 750/000 to 800/000 Toman. The company distributes electricity, per kilowatt hour of electricity generated 832 Toman buys.

Reporter: What is the power generation capacity of the system?

Ms. Mohamadi: The installed photovoltaic system capacity is 5 kilowatts. Annually produces 9000kwh of electricity.

Reporter: What is the cost of purchasing and installing this system?

Ms. Mohamadi: The cost of this system about 25 milion to 27 milion.

Reporter: Well, then, the first few years of this system is not profitable. It is true?

Ms. Mohamadi: Yes, the life of solar systems is 20 years. The first four years are the return of capital and the next 16 years of profitability.

Reporter: What is a solar system components?

Ms. Mohamadi: For installation a solar system, we need the following components: Solar Panel, Controller charge, Battery, Inverter.

Reporter: Please give us a brief description of each component.

Ms. Mohamadi: ok,

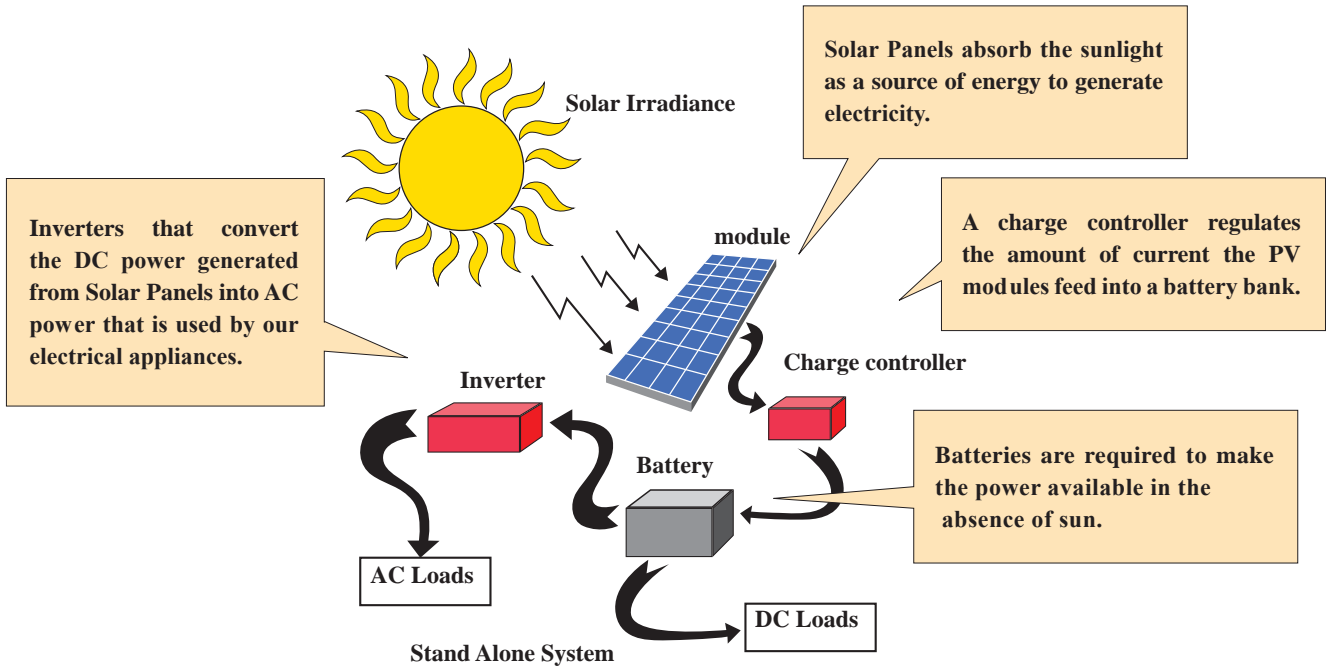

Reporter: Thank you, we wish you more success and progress in your work.

Activity

فعالیت

The parts of charge controller catalogue are shown. Determine the Persian equivalents of the following technical terms and write them.

①	PV Terminals	⑥	Load Switch Button
②	Battery Terminals	⑦	Battery status LED indicator
③	Load Terminals	⑧	Load status LED indicator
④	USB output interface (LS E series only)	⑨	Charging status LED indicator
⑤	Mounting Hole $\Phi 4.5$		

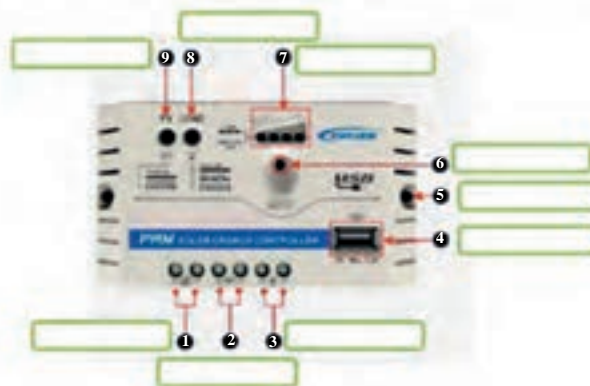

Activity

فعالیت

Please study a Inverter catalogue and translate important section.

History



The term 'horse power' is largely credited to James Watt, in the late 1700s. Watt was a Scottish engineer who invented a number of improvements to steam engines, which he then (in partnership) began to manufacture and sell (the first units going into service in 1776).

Most of Watt's potential clients were using horses, so he soon found that in order to market his engines, he needed to express the power of his engines in terms of how many horses a given engine would replace. For this purpose, he first calculated the average power of a horse, which he termed 'horsepower'. He then specified for each of his engines how much 'horsepower' it had (i.e. of how many horses it had the equivalent power of). Due to the success of his steam engine business, the term 'horsepower' came to be recognized. His competitors and other machine manufacturers copied his approach, also expressing the power of their engines in 'horsepower', which resulted in it becoming a standard measure of power.

Activity

فعالیت

Convert horsepower to kilowatts in the table.

Electrical horsepower to kilowatts

This is the type of horsepower used for electrical engines. Each unit of

electrical horsepower is equal to exactly 746 watts or 0.746kw.

$$1 \text{ hp(E)} = 746 \text{ W} = 0.746 \text{ kW}$$

So the power conversion of horsepower to kilowatts is given by:

$$P(\text{kw}) = 0.746 \cdot P(\text{hp})$$

hp (horse power)	kw (kilo watt)
5	
10	
15	
20	
30	

Reading

Solar Water Pumping System for Agriculture

One of the major problems common agricultural pumps to extract water from agricultural fields, far from the global grid electricity.

On the other hand, the high cost of power transmission and maintenance of power distribution lines, and the cost of purchasing diesel generators and their fuel and maintenance has led to the use of solar pumps is an appropriate solution to replace the stated cases.

Lower maintenance costs, longer life and, most importantly, the cost of free source solar system water pumps increase its cost-effectiveness.

Solar pumps essentially are a collection of solar PV panels, AC or DC pumps and the associated electronics that have been optimized for high efficiency operations.

These pumps when maintained well last for more than 15 years on the field.

An illustrative diagram and an operational pump set are shown below.

Solar pumps are divided into two groups of direct and alternating current. Because the output voltage of the solar module is Direct, direct current pumps are more common.

Certainly, the ability of pumps is less than that of alternating current pumps.

Generally, solar electropumps can be used for permanent magnetic electromotors up to 13

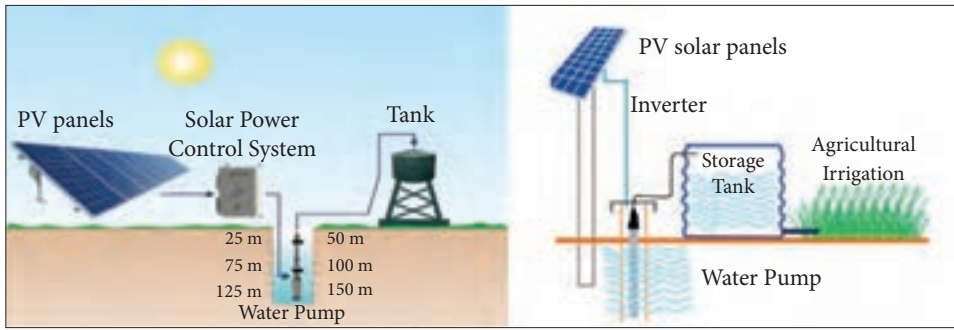

horsepower, and for conventional 3 to 10 horsepower electric motors.

If used with alternating electropumps, this power will be higher than 10 horsepower. But, in this last model, you should use a direct voltage converter to the alternating voltage (inverter). Although the price of an alternating electromotor is cheaper than direct, the price of the converter will also be expensive.

A. read each statement and decided whether it is true or false. Write T before true statement and F before false statements.

- 1_ Solar system water pumps have a short life and expensive maintenance cost.
- 2_ These pumps when maintained well last for more than 25 years on the field.
- 3_ The ability of direct current pumps is less than that of alternating current pumps.
- 4_ In this AC electropump, you should use a direct voltage converter to the alternating voltage.
-5_ The price of adirectelectromotor is cheaper than alternating electropump.
-6_ In the ACElectromotor, the price ofinverter will be so expensive.

B. Please answer the questions.

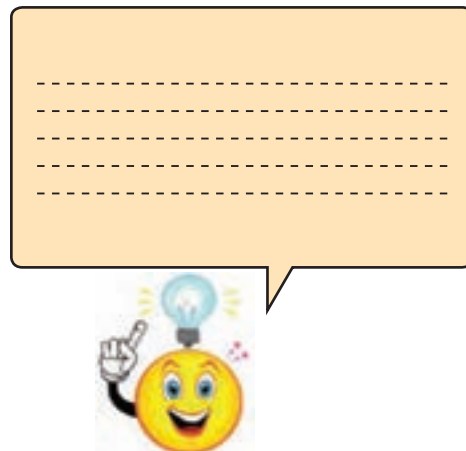
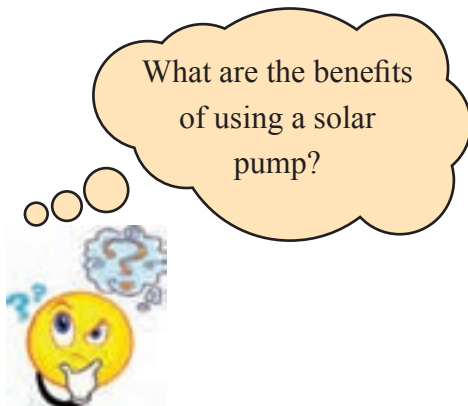

What types of solar pumps are there?

Which type of solar pumps is more common?

What type of solar pump is economically better? Why?

Which pump is used with inverter?



C. See the movie.

پلاک موتور الکتریکی (Electromotor nameplate)

Motor nameplate is normally located on all produced electric motors. Understanding nameplate information can be hard sometimes, but is essential. In most countries it is a requirement for manufacturers to display all information on the motor's nameplate, but often this is not the case. many Essential Information Found On Motor's Nameplate:

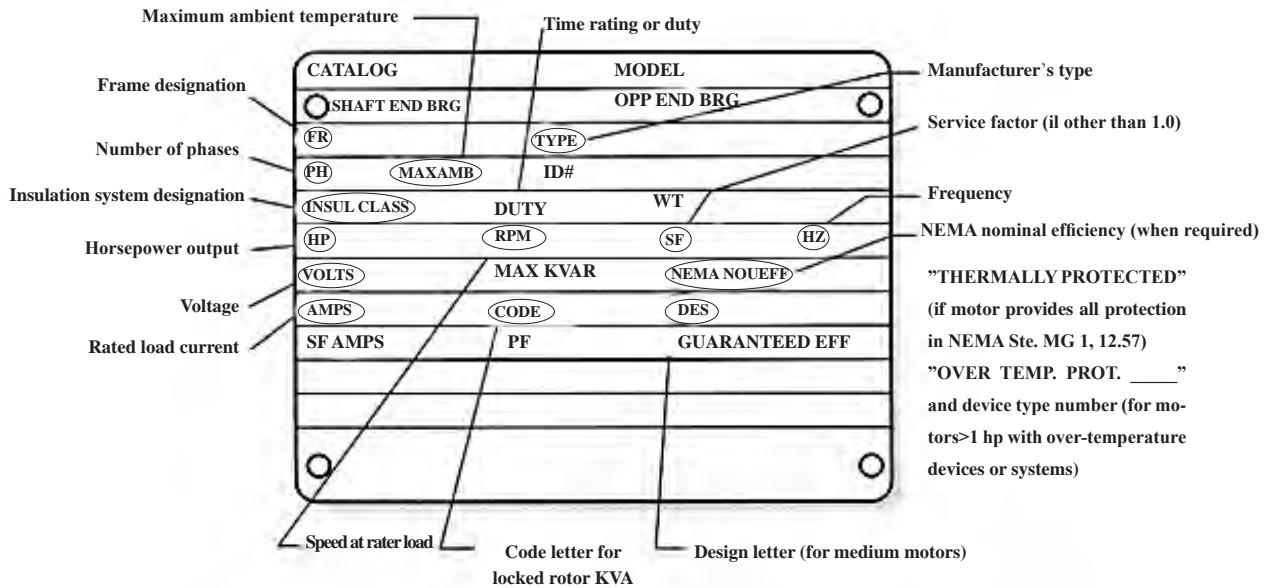

For example, explained important items input in Nameplate.

Voltage

This data tells you **at which voltage the motor is made to operate**. Nameplate-defined parameters for the motor such as power factor, efficiency, torque and current are at rated voltage and frequency. When the motor is used at other voltages than the voltage indicated on the nameplate, its performance will be affected.

Frequency

Usually for motors, **the input frequency is 50 or 60 Hz**. If more than one frequency is marked on the nameplate, then other parameters that will differ at different input frequencies have to be indicated on the nameplate as well.

Type

Some manufacturers use type to define the motor as single_phase or poly_phase, single_phase or multi_speed or by type of construction. **Nevertheless, there are no industry standards for type.**

Power factor

Power factor is indicated on the nameplate as either “PF” or “P.F” or $\cos \phi$. Power factor is an expression of the ratio of active power (W) to apparent power (VA) expressed as a percentage.

Numerically expressed, power factor is equal to cosine of the angle of lag of the input current with respect to its voltage.

The motor’s nameplate provides you with the **power factor for the motor at fullload**.

Enclosure

Enclosure classifies a motor as to its degree of protection from its environment and its method of cooling. Enclosure is shown as **IP or ENCL** on the nameplate.

kW or horsepower

kW or horsepower (HP) is an expression of the motor’s mechanical output rating – that is it’s ability to deliver the torque needed for the load at rated speed.

Activity

فاعليت

Write the parameters from the motor’s nameplate

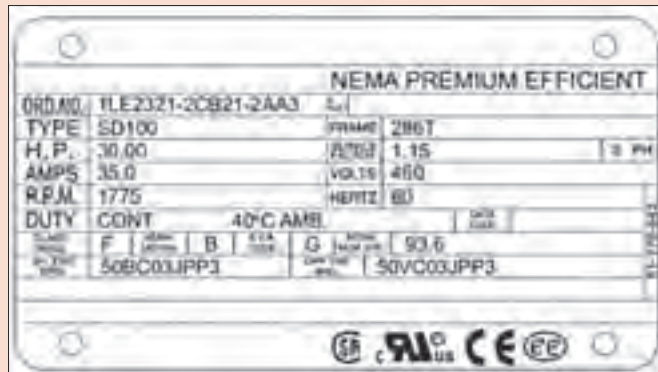

- Voltage :
- Frequency:
- Type:
- Power factor:
- Enclosure :
- kW or horsepower :

منحنی مشخصه کلید خودکار مینیاتوری (MCB)

MCB or miniature circuit breakers are electromechanical devices which protect an electric circuit from an overcurrent.

Miniature Circuit Breakers (MCBs)

Tripping Characteristics

Characteristics according to IEC/EN 60898.

- B Quick-acting, for household applications
- C Slow-acting, for applications with high starting currents (e.g. motors)
- D Very slow-acting, for industrial applications like motors for compressors and pumps

Tripping Characteristic B

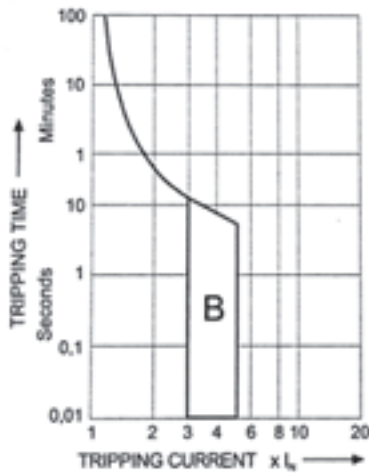

Tripping Characteristic C

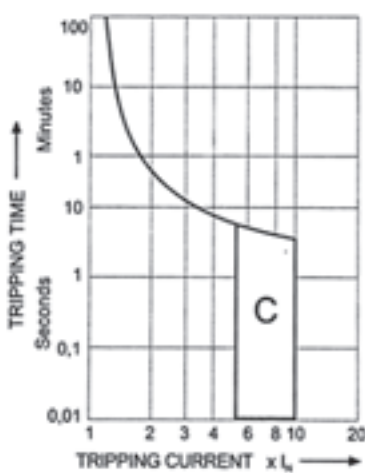

Tripping Characteristic D

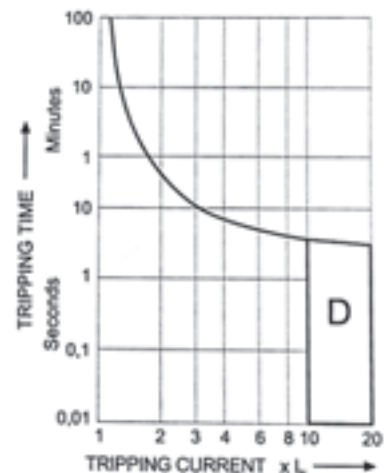

Now, fill the blank according to the curves.

Type C MCB trips between times full load current.

Type B MCB trips between times full load current.

Activity

فعاليات

Please search and study about application of each kinds of MCBs.

ارزشیابی مبتنی بر شایستگی پودمان کسب اطلاعات فنی (زبان فنی)

استاندارد ارزشیابی پیشرفت تحصیلی مبتنی بر شایستگی درس دانش فنی تخصصی الکتروتکنیک					
نمره	شاخص تحقیق	نتایج مورد انتظار	استاندارد عملکرد (کیفیت)	تکالیف عملکردی (واحدهای یادگیری)	عنوان پودمان
۳	از کل سؤالات به هفت تا ده سؤال به طور کامل پاسخ دهد.	بالاتر از حد انتظار	درک متون فنی انگلیسی پودمان زبان فنی - برگردان متون فنی انگلیسی پودمان به فارسی - درک و تفسیر کاتالوگ فنی انگلیسی پودمان - برگردان کاتالوگ فنی انگلیسی پودمان به فارسی	کسب اطلاعات فنی (زبان فنی)	پودمان ۵
۲	از کل سؤالات به شش سؤال به طور کامل پاسخ دهد.	در حد انتظار			
۱	از کل سؤالات به یک تا پنج سؤال به طور کامل پاسخ دهد.	پایین تر از حد انتظار			
				نمره مستمر از ۵	
				نمره شایستگی پودمان	
				نمره پودمان از ۲۰	

هدف‌گذاری و سنجش:

برای کسب شایستگی در این پودمان اگر هنرجو:

از کل سؤالات به یک تا پنج سؤال به‌طور کامل پاسخ دهد شایستگی پایین‌تر از حد انتظار خواهد بود.

از کل سؤالات به شش سؤال به‌طور کامل پاسخ دهد شایستگی در حد انتظار خواهد بود.

از کل سؤالات به هفت تا ده سؤال به‌طور کامل پاسخ دهد شایستگی بالاتر از حد انتظار خواهد بود.

توجه: سؤالات ارائه شده همگی هم‌ارزش بوده و در سطح یادگیری در حد انتظار است. معیار ارزشیابی نتیجه‌محور است.

سؤال ۱- (۲ نمره)

سؤال ۲- (۲ نمره)

سؤال ۳- (۲ نمره)

سؤال ۴- (۲ نمره)

سؤال ۵- (۲ نمره)

سؤال ۶- (۲ نمره)

سؤال ۷- (۲ نمره)

سؤال ۸- (۲ نمره)

سؤال ۹- (۲ نمره)

سؤال ۱۰- (۲ نمره)

- ۱- برنامه درسی درس دانش فنی تخصصی رشته الکتروتکنیک، سازمان پژوهش و برنامه‌ریزی آموزشی، ۱۳۹۴
- ۲- مبانی ماشین‌های الکتریکی، پ.س.سن، مهرداد عابدی و محمد تقی نبوی، نشر بصیر
- ۳- مدارهای الکتریکی، سری سوم
- ۴- قطعات و مدارات الکترونیک، نسلسکی اشتاد، قدرت سپید نام و...، نشر خراسان، ۱۳۷۸
- ۵- کاتالوگ‌ها و دستورالعمل بهره‌برداری اینورتر، ولت‌متر و تجهیزات فتوولتاییک
- ۶- الکترونیک صنعتی، لندر سریل، معتمدی نژاد و...، نشر خراسان، ۱۳۷۵
- ۷- متون و کتاب‌های فنی برق به زبان انگلیسی
- ۸- محصولات شرکت‌های داخلی سازنده ترانسفورماتور



سازمان پژوهش و برنامه‌ریزی آموزشی جهت ایفای نقش خطیر خود در اجرای سند تحول بنیادین در آموزش و پرورش و برنامه درسی ملی جمهوری اسلامی ایران، مشارکت معلمان را به‌عنوان یک سیاست اجرایی مهم دنبال می‌کند. برای تحقق این امر در اقدامی نوآورانه سامانه تعاملی بر خط اعتبارسنجی کتاب‌های درسی راه‌اندازی شد تا با دریافت نظرات معلمان درباره کتاب‌های درسی نونگاشت، کتاب‌های درسی را در اولین سال چاپ، با کمترین اشکال به دانش‌آموزان و معلمان ارجمند تقدیم نماید. در انجام مطلوب این فرایند، همکاران گروه تحلیل محتوای آموزشی و پرورشی استان‌ها، گروه‌های آموزشی و دبیرخانه راهبری دروس و مدیریت محترم پروژه آقای محسن باهو نقش سازنده‌ای را بر عهده داشتند. ضمن ارج نهادن به تلاش تمامی این همکاران، اسامی دبیران و هنرآموزانی که تلاش مضاعفی را در این زمینه داشته و با ارائه نظرات خود سازمان را در بهبود محتوای این کتاب یاری کرده‌اند به شرح زیر اعلام می‌شود.

اسامی دبیران و هنرآموزان شرکت کننده در اعتبارسنجی کتاب دانش فنی تخصصی رشته الکتروتکنیک کد ۲۱۲۲۶۳

ردیف	نام و نام خانوادگی	استان محل خدمت	ردیف	نام و نام خانوادگی	استان محل خدمت
۱	سید محمد هاشم آبادی	خراسان رضوی	۱۴	رحیم اسعدی	آذربایجان غربی
۲	فتح اله مرادپور	مرکزی	۱۵	مهدی حامد یوسفیان	خراسان رضوی
۳	محمدصادق صدیقی	شهر تهران	۱۶	سینا جوادی مهریزی	یزد
۴	هادی بیدختی	خراسان جنوبی	۱۷	مصطفی حقمرادی نیا	همدان
۵	مصطفی پروین	سیستان و بلوچستان	۱۸	رفیع نبوی	اردبیل
۶	ابوالفضل طالبیان	اصفهان	۱۹	وحید زمانی	کرمان
۷	ولی الله عباسی	سمنان	۲۰	امین احراری	خراسان جنوبی
۸	حسین علی قاسمی دشتی	قم	۲۱	علی نوذری	خوزستان
۹	احمد مرادقلی	سیستان و بلوچستان	۲۲	محمد خیجی	گلستان
۱۰	خیراله رحمانی	قزوین	۲۳	مسعود فلاح	گیلان
۱۱	وحید ذاکری بنوبندی	هرمزگان	۲۴	رضا پورمراد	آذربایجان شرقی
۱۲	محمد کاظمی	مازندران	۲۵	حمید چراغیان	ایلام
۱۳	بهمن علیقلی زاده	اردبیل			

هنرآموزان محترم، هنرجویان عزیز و اولیای آنان می‌توانند نظرهای اصلاحی خود را درباره مطالب این کتاب از طریق نامه
به نشانی تهران - صندوق پستی ۴۸۷۴ / ۱۵۸۷۵ - گروه درسی مربوط و یا پیام نگار tvoccd@roshd.ir ارسال نمایند.

وب‌گاه: tvoccd.oerp.ir

دفترتایف کتاب‌های درسی فنی و حرفه‌ای و کار دانش

